



**GENERAL DESCRIPTION**

The GP5213 is a monolithic PWM high-efficiency LED driver control IC. It allows efficient operation of High Brightness (HB) LEDs from voltage sources ranging from 8VDC up to 550VDC. The GP5213 controls an external NMOSFET at fixed switching frequency up to 500kHz. The frequency can be programmed by a single resistor. The LED string is driven at constant current to provide constant light output and enhanced reliability.

The LED drive current can be programmed by a single resistor at CS pin to set the drive current from a few milliamps up to a preset high drive current.

Linear dimming can be achieved through input a 0V to 250mV DC voltage to ADJ pin.

By grounding the PWM pin the chip can be disabled and draw less than 1mA current.

**FEATURES**

- 8V to 550V input range
- >90% Efficiency
- Constant-Current LED Driver
- LED driver current from a few mA to preset High current Drive
- Linear Dimming via ADJ pin
- PWM Dimming via PWM pin
- LED string from one to hundreds of Diodes
- Input Voltage Surge ratings up to 550V

**APPLICATIONS**

- MR16
- LED lighting
- Automotive
- Out door LED lighting

**PACKAGE PIN OUT**

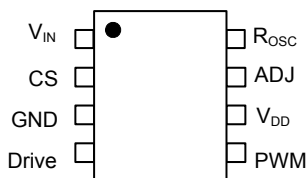

**TYPICAL APPLICATION CIRCUIT**

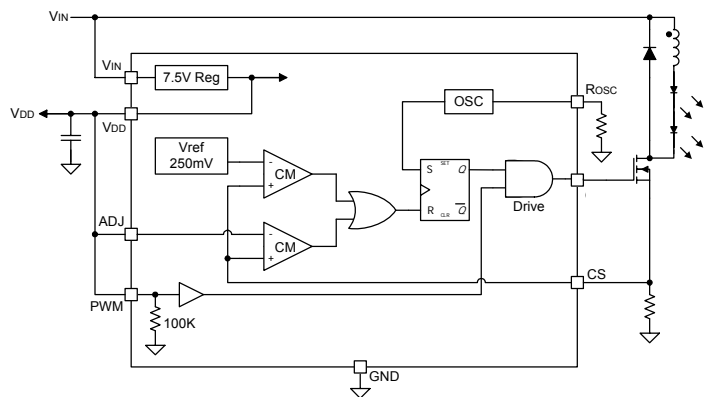

**ORDER INFORMATION**

GP5213D      HB LED Driver SO8 package  
 GP5213M      HB LED Driver DIP8 package

**Marking Information**

wwzz :    zz : Year  
           ww : production week code

1. Order quantity  
 SO8 order minimum 3,000 ea per Tape/Reel  
 DIP8 order minimum 2,000 ea pack with tube.
3. GPS Pb-free plus anneal products employ with molding compounds, die attach material and and 100% matte tin plate termination finish which are Rohs compliant and compatible with both SnPb and Pb-free soldering operations.

**BLOCK DIAGRAM and Typical Application Circuit**

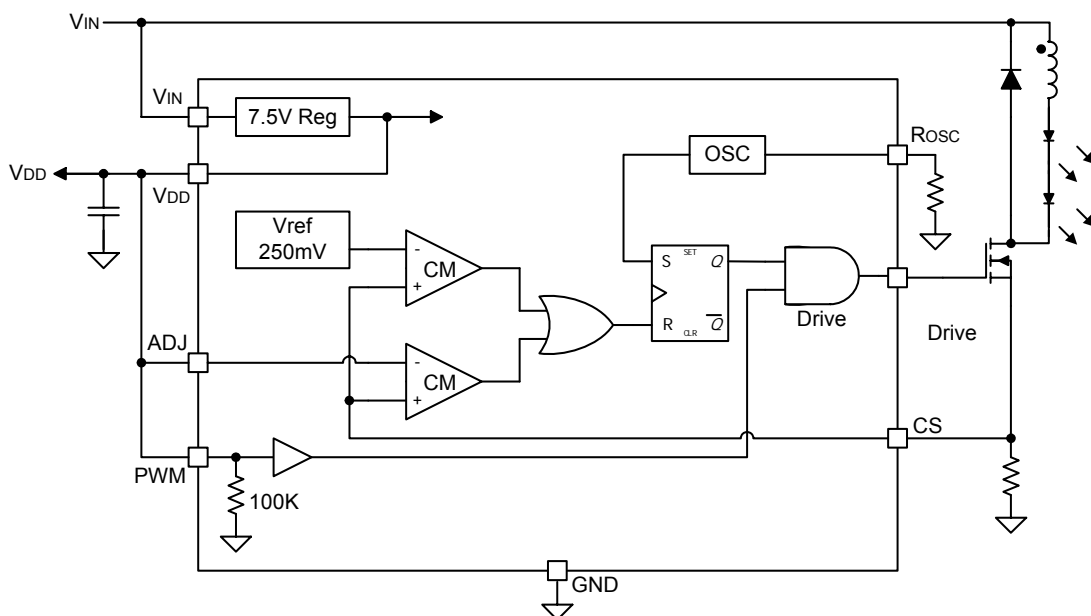

Figure 1

## Pin Description

Pin	Pin Name	Description
1	V <sub>IN</sub>	Input voltage 8V to 550V DC,
2	CS	Senses LED string current
3	GND	Device ground
4	Drive	Drives the gate of the external NMOSFET
5	PWM	Low Frequency PWM Dimming pin, also as Enable input. Internal 100kΩ resistor pull-down to GND
6	V <sub>DD</sub>	Internally regulated supply voltage with 7.5V nominal value. A 1μF storage capacitor is used to provide storage when the rectified AC input is near the zero crossings.
7	ADJ	Linear Dimming by changing the current limit threshold at current sense comparator
8	Rosc	Oscillator control. A resistor connected between this pin and ground sets the PWM frequency.

ABSOLUTE MAXIMUM RATINGS (Note a)	
V <sub>in</sub> Voltage	550V
V <sub>DD</sub> Voltage	13V
Operating Junction Temperature Range	-40°C to 125°C
Storage Temperature Range	-55°C to 150°C
Package Thermal Resistance, SO8, θ <sub>JA</sub>	165°C/W
Power dissipation (P <sub>D</sub> ), T <sub>A</sub> = 25°C, SO8	757mW
Package Thermal Resistance, DIP8, θ <sub>JA</sub>	95°C/W
Power dissipation (P <sub>D</sub> ), T <sub>A</sub> = 25°C, DIP8	1.31W
Lead Temperature (Soldering, 5 sec.)	260°C
Note a: Exceeding these ratings could cause damage to the device. All voltages are with respect to Ground.	

## Characterization

Symbol	Description	Conditions	Min	Typ	Max	Units
$V_{INDC}$	Input DC supply voltage range	DC input voltage, fosc=25kHz,	8.0		550	V
$I_{INsd}$	Shut-Down mode supply current	Pin PWM to GND, $V_{IN} = 8V$		0,5	1,0	mA
$V_{DD}$	Internally regulated voltage	$V_{IN} = 8-550V$ , fosc=25kHz, $I_{DD(ext)}=0$ , pin Drive open	7.0	7.5	8.0	V
$V_{DDmax}$	Maximal pin $V_{DD}$ voltage	When an external voltage applied to pin $V_{DD}$			13.5	V
$I_{DD(ext)}$	$V_{DD}$ current available for external circuitry <sup>1</sup>	$V_{IN} = 8V$			1.0	mA
UVLO	$V_{DD}$ undervoltage lockout threshold	$V_{IN}$ rising	6.4	6.7	7.0	V
$\Delta UVLO$	$V_{DD}$ undervoltage lockout hysteresis	$V_{IN}$ falling		500		mV
$V_{EN(lo)}$	Pin PWM input low voltage	$V_{IN} = 8-550 V$			1.0	V
$V_{EN(hi)}$	Pin PWM input high voltage	$V_{IN} = 8-550 V$	2.4			V
RLN	Pin PWM pull-down resistance	$V_{EN} = 5V$	100	120	150	k $\Omega$
$V_{CS(hi)}$	Current sense pull-in threshold voltage	@TA = -40°C to +85°C	225	250	275	mV
$V_{DR(hi)}$	Drive high output voltage	$I_{OUT} = -20mA$	$V_{DD}-0.2$		$V_{DD}$	V
$V_{DR(lo)}$	Drive low output voltage	$I_{OUT} = 20mA$	0		0.2	V
fosc	Oscillator frequency	Rosc = 1.00 M $\Omega$ Rosc = 223 k $\Omega$ Rosc = 32 k $\Omega$	20 80 450	23 90 500	30 100 550	kHz
$D_{MAXht}$	Maximum Oscillator PWM Duty Cycle	$F_{PWMhf} = 25kHz$ , at Drive, CS to GND			100	%
$V_{ADJ}$	Linear Dimming pin voltage range	@TA = <85°C, $V_{IN} = 12V$	0		250	mV
$T_{BLANK}$	Current sense blanking interval	$V_{CS} = 0.55V_{ADJ}$ , $V_{ADJ} = V_{DD}$	150	190	230	ns
$t_{DELAY}$	Delay from CS trip to Drive low	$V_{IN} = 12V$ , $V_{ADJ} = 0.15$ , $V_{CS} = 0$ to 0.22V after $T_{BLANK}$			200	ns
$I_{Driveso}$	Drive shot-circuit current	$V_{Drive} = 0$ , $V_{DD} = 7.5 V$		-30		mA
$I_{Drivesi}$	Drive sinking current	$V_{Drive} = 7,5 V$ , $V_{DD} = 7.5 V$		30		mA

\*  $V_{in}$  at slow increase of an entrance voltage up to 550 V (during 500 ms).

## Detailed Description

The GP5213 is a low cost solution of off-line buck, boost or buck boost converter controller chip design for driving HB LED strings or arrays. It can be operated from either AC line or DC voltage between 7.5V to 550V. A passive power factor correction circuit can be used as an option. The GP5213 can drive up to hundreds of HB (High Brightness) LEDs. The LED arrays can be configured as a series/parallel connection. The GP5213 regulates constant LED driving current ensures controlled brightness of the LEDs, and extends LED lifetime. The GP5213 has a PWM pin function as Enable pin and allows PWM control of LED brightness.

The ADJ pin in GP5213 also can input a DC control voltage from 0V to 250mV to program LED drive current and achieve LED brightness control.

GP5213 includes an internal high-voltage linear regulator which powers all internal circuits. The  $V_{DD}$  allows to serve as a bias supply to low voltage external circuits.

## LED Drive Operation

The GP5213 can control all types of converters, non-isolated or isolated, operating in discontinuous or continuous conduction modes. When the Drive current activated the external power NMOSFET, the input energy stores in an inductor and depending on the converter type, may partially deliver the energy to the LEDs. The energy stores in the inductor is further delivered to the output during the off-cycle of the power NMOSFET and drives the current to the string of LEDs.

When  $V_{DD}$  pin voltage exceeds the UVLO threshold the Drive pin is enabled. The drive current is controlled by means of limiting peak current in the external NMOSFET. A current sense resistor connected in series with the source node of the NMOSFET. The voltage across the sense resistor is feedback to the CS pin. When the CS pin voltage over 250mV threshold the power NMOSFET turn off. It can applying the DC

voltage of 0V to 250mV to the ADJ pin to program the LED current as well. An external Capacitor can be connected to the ADJ pin when soft start is required.

## Setting LED Current

For example if the peak-to-peak ripple current in the inductor is 150mA to get a 700mA LED current, the sense resistor should be calculated as  $250\text{mV} / (700\text{mA} + 0.5 \times 150\text{mA}) = 0.32\Omega$ .

## Dimming

By input 0V to 250mV DC voltage to ADJ pin to change the current or switching the current on and off while maintaining the constant current drive. When Voltage is higher than 250 mV will not change the output current.

Or control the LED brightness by varying the duty of the output drive current through a PWM signal input to the PWM pin.

## Operating Frequency

The operating frequency of the internal oscillator can be programmed between 20kHz to 500kHz.

$$F_{osc} = 25000 / (R_{osc}(\text{k}\Omega) + 22) \text{ kHz}$$

## Inductor Design

The inductor for the application can be calculated from the desired peak-to-peak LED ripple current. The ripple current is selected to be 30% of the nominal LED current. For instance, the nominal current is 500mA.

Then next step is estimate the total voltage drop across the LED string. In case of total 5 HB LEDs and each diode has a forward voltage drop of 3.0V at its nominal current. The total LED voltage is 15V.

The nominal rectified input voltage  $V_{in} = 120\text{V} \times 1.41 = 169\text{V}$ , the switching duty ratio can be calculated as:

$$D = V_{LEDs} / V_{in} = 15 / 169 = 0.0887$$

Then, select the switching frequency as 200kHz, the required on-time of the

MOSFET can be calculated:

$$T_{on} = D / f_{osc} = 0.443 \text{ us}$$

The required inductor value calculate as below

$$L = (V_{in} - V_{LEDS}) \times T_{on} / (0.3 \times I_{LED}) = 455\mu\text{H}$$

### Input Bulk Capacitor Design

An input filter capacitor should be designed to hold the rectified AC voltage above twice the LED string voltage within AC line cycle. Assuming 15% relative voltage ripple across the capacitor, the following formula to design the minimum value of the bulk input capacitor

$$C_{min} = I_{LED} \times V_{LEDS} \times 0.06 / V_{in}^2$$

$C_{min} = 16\mu\text{F}$ , a value of 16  $\mu\text{F}$  /250V can be selected.

### Output Open circuit Protection

In bulk topology design, the LEDs are connected in series with the inductor. It is no need for any protection against an open circuit condition in the LED string. In contrast, the design of buck-boost or the Flyback topology the GP5213 may cause excessive voltage stress of the NMOSFET and rectifier diode and have potential failure. In this kind of application, the GP5213 can be disabled by pulling PWM pin to ground in case of over voltage condition detected.

### Enable

The GP5213 can be turned off by pulling the PWM pin to ground and draws quiescent current less than 1mA.

### Buck Converter Operation

When the LED string voltage is lower than the input supply voltage the buck conversion topology can be used. However, the input voltage must be maintained higher than 2 times the forward voltage drop across the LEDs. This limitation is related to the output current instability that may happen when the GP5213 buck converter operates at a duty cycle greater than 0.5.

This instability reveals itself as an oscillation of the output current at a sub-harmonic of the Switching frequency.

### Flyback (Buck-Boost) Design

When the forward voltage drop of the LED string is higher, equal or lower than the input supply voltage the Buck-Boost topology can be designed. For instance, for automotive battery (12V0 supply and output string consists of three to six HB LEDs for tail signal or car's interior lights application.

In the Buck-Boost converter, the energy from the input source is first stored in the inductor when the switching MOSFET is On. The energy is the delivered to the output during the Off time of the MOSFET. When the energy stored in the Flyback inductor does not fully deleted by the next switching cycle (continuous conduction mode) the DC conversion between input and output voltage is express as ;

$$V_{out} = - V_{in} \times D / (1-D)$$

The output voltage can be either higher or lower than the input voltage depending on the duty ratio.

Take an automotive LED driver example which needs to drive three HB LEDs at 500mA.

The automotive nominal input voltage  $V_{in}=12\text{V}$ , then the nominal duty ratio can be determined as

$$D = V_{LEDS} / (V_{in} + V_{LEDS}) = 9 / (12+9)=0.43$$

Then set the switching frequency as 50KHz. The MOSFET on time can be calculate as

$$T_{on} = D / F_{osc} = 8.6 \text{ us}$$

The inductor value is

$$L = V_{in} \times T_{on} / (0.3 \times I_{LED}) = 0.688\text{mH}$$

### Output Capacitor

The buck-boost converter needs an output filter capacitor to deliver power to the LED string during MOSFET On time, when the Flyback inductor current is diverted from the output of the converter.

For the purpose of average the current in the LED, a capacitor must present impedance to the switching output AC ripple current that is much lower than the dynamic impedance  $R_{out}$  of the LED string. If assume  $R_{out}=3\Omega$  In the example, in order to attenuate the switching ripple by a factor of 10, a capacitor

with equivalent series (ESR) of  $0.3\Omega$  is needed. A chip SMT tantalum capacitor can be selected for this application.

### Application Circuit

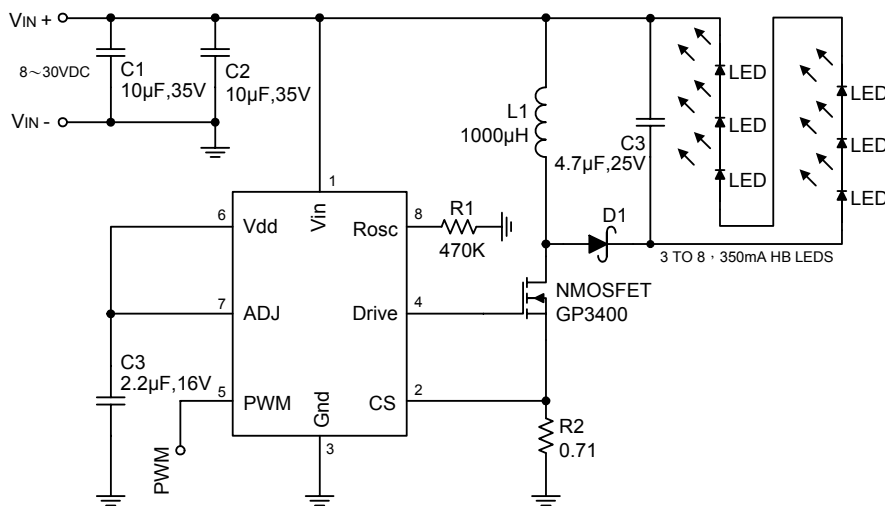

Figure 2, Buck-Boost drive 350mA to HB LEDs

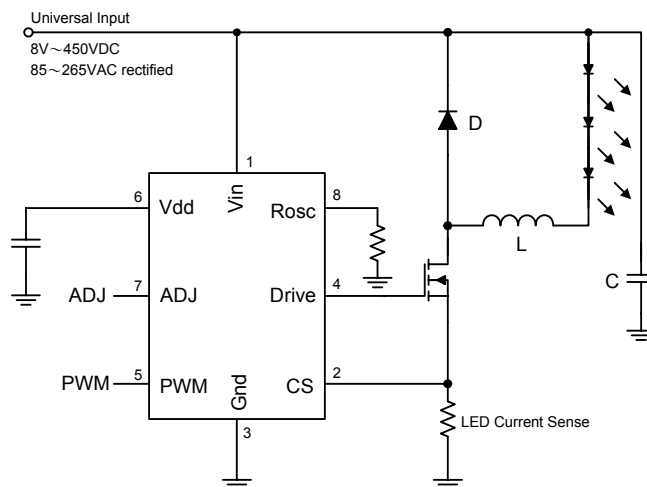

Figure 3, Buck Driver

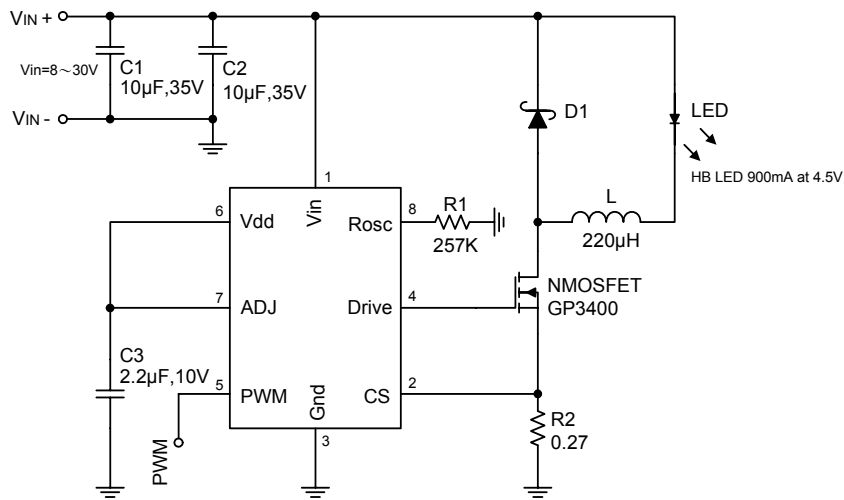

Figure 4, Buck Driver 900mA to a single HB LED

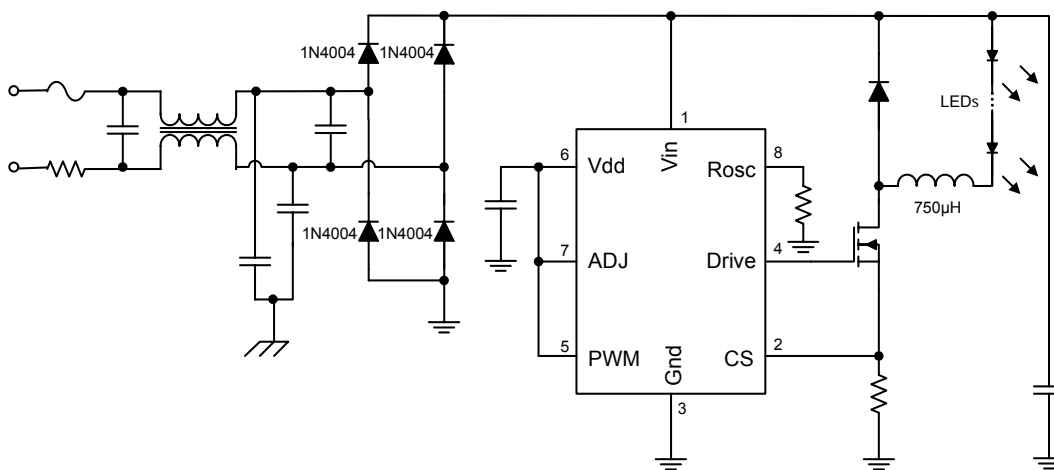
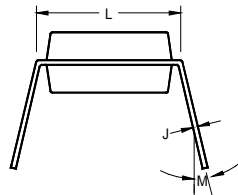
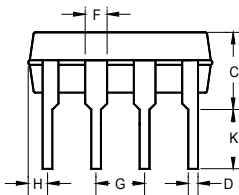
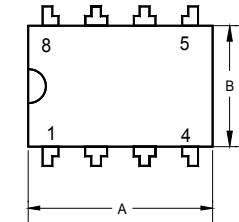

Figure 5 Buck Driver

## Package Information

### 8-Pin Plastic DIP Package



	INCHES			MILLIMETERS		
	MIN	TYP	MAX	MIN	TYP	MAX
A	0.355	0.365	0.400	9.02	9.27	10.16
B	0.240	0.250	0.280	6.10	6.35	7.11
C	-	-	0.210	-	-	5.33
D	-	0.018	-	-	0.46	-
F	-	0.060	-	-	1.52	-
G	-	0.100	-	-	2.54	-
H	0.050	-	0.090	1.27	-	2.29
J	0.008	-	0.015	0.20	-	0.38
K	0.115	0.130	0.150	2.92	3.30	3.81
L	0.300 BSC.			7.62 BSC.		
M	-	7°	15°	-	7°	15°

Note: For 8-pin Plastic package, 60 units per tube

### 8-Pin Plastic SO Package

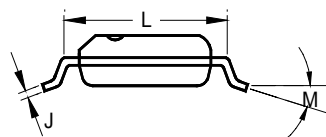
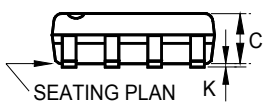
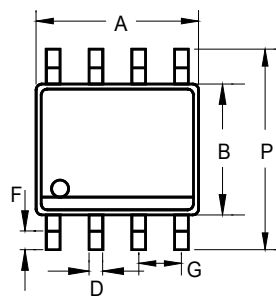

	INCHES			MILLIMETERS		
	MIN	TYP	MAX	MIN	TYP	MAX
A	0.183	-	0.202	4.65	-	5.13
B	0.144	-	0.163	3.66	-	4.14
C	0.068	-	0.074	1.35	-	1.88
D	0.010	-	0.020	0.25	-	0.51
F	0.015	-	0.035	0.38	-	0.89
G	0.050 BSC			1.27 BSC		
J	0.007	-	0.010	0.19	-	0.25
K	0.005	-	0.010	0.13	-	0.25
L	0.189	-	0.205	4.80	-	5.21
M	-	-	8°	-	-	8°
P	0.228	-	0.244	5.79	-	6.20

Note: for 8 pin S.O.I.C., 100 units per tube

Green Power Semiconductor Inc. (GPS) reserves the right to make changes to its products or to discontinue any integrated circuit product or service without notice, and advises its customers to obtain the latest version of relevant information to verify, before placing orders, that the information being relied on is current.

Some applications using integrated circuit products may involve potential risks of death, personal injury, or severe property or environmental damage. GPS integrated circuit products are not designed, intended, authorized, or warranted to be suitable for use in life-support applications, devices or systems or other critical applications. Use of GPS products in such applications is understood to be fully at the risk of the customer. In order to minimize risks associated with the customer's applications, the customer should provide adequate design and operating safeguards.

GPS assumes no liability to customer product design or application support. GPS warrants the performance of its products to the specifications applicable at the time of sale.